

CAD FILE:

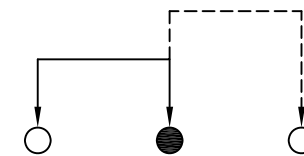

SCHEMATIC (NON-SHORTING)

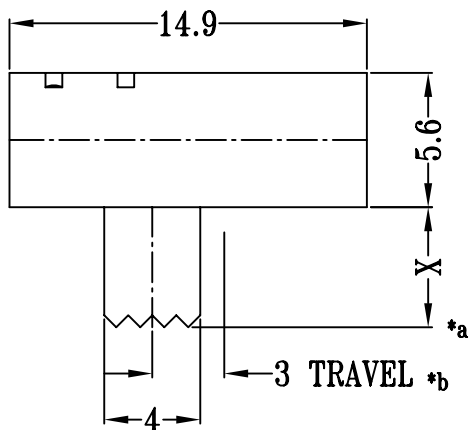
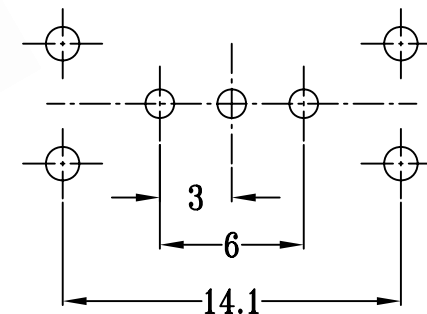
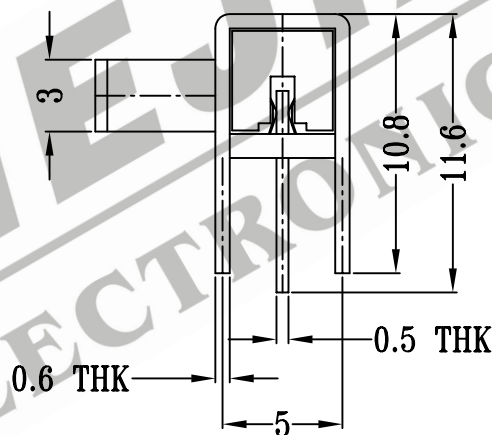
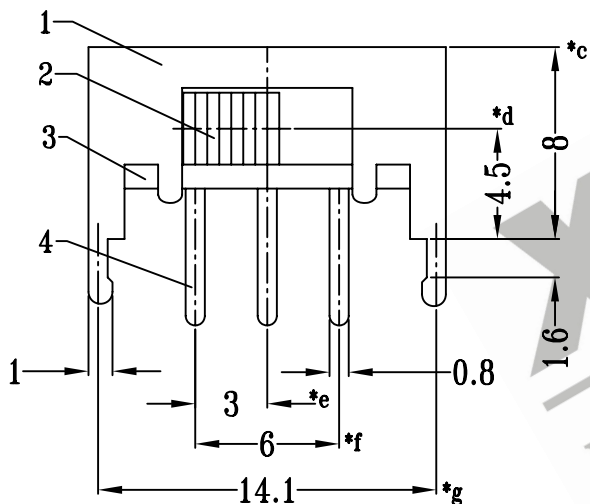

P.C.B LAYOUT

注:带*表示关键尺寸(7个)

NO.	PART NAME	MATERIAL	Q'TY	FINISHING	TOLERANCE UNLESS SPECIFIED	SHENZHEN XIEJIA ELECTRONICS CO.,LTD.				
8										
7	STEEL BALL	STEEL	1	NATURAL						
6	SPRING	STEEL WIRE	1	TEMPER	WITHIN: 1.5±0.1mm OVER : 1.5±0.2mm	ISSUE	DATE	DESCRIPTIONS		APPD.
5	CONTACT CLIP	PBS STRIP	1	Ag PLATED						
4	TERMINAL	BRASS STRIP	3	Ag PLATED OVER Ni PLATED						
3	BASE	PHENOLIC RESIN	1	NATURAL	TITLE : HORIZONTAL SLIDE SWITCH	UNIT : MM	DRWG NO.: XJ-DR-SK12F16-00			
2	KNOB	POM	1	BLACK	MODEL: SK-12F16	SCALE: 3:1	DWN.	ZHOUYU	2005-7-16	
1	FRAME	STEEL STRIP	1	Zn PLATED			CHK'D	FANGYING	2005-7-16	
					ALL MATERIALS MUST BE COMPLIANT TO ROHS		APPD.	KANGXINAN	2005-7-16	